

*J. A. Cleveland.*

*Turning Lathe.*

*N<sup>o</sup> 79,729.*

*Patented Jul. 7, 1868.*

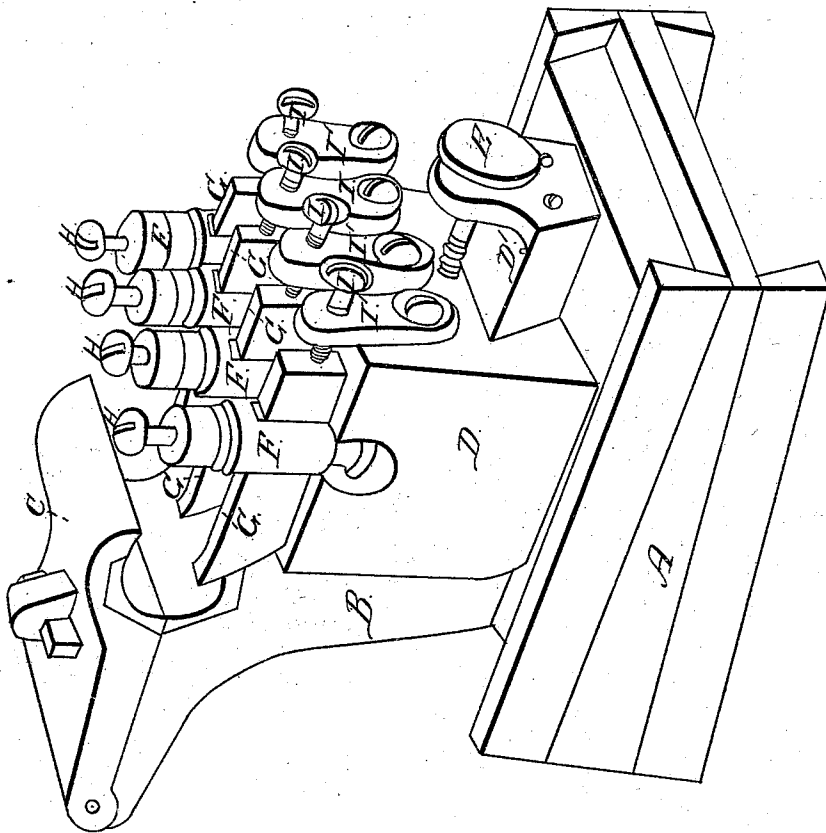

*Witnesses*  
*J. H. Sprague*  
*Chas. F. Clausen*

*Inventor.*  
*J. A. Cleveland*  
*by*  
*D. P. Holloman & Co.*  
*Attys.*

United States Patent Office.

JUDSON A. CLEAVELAND, OF LA FAYETTE, INDIANA.

Letters Patent No. 79,729, dated July 7, 1868.

IMPROVEMENT IN TOOL FOR TURNING SHAFTING, &c.

The Schedule referred to in these Letters Patent and making part of the same.

TO ALL WHOM IT MAY CONCERN:

Be it known that I, JUDSON A. CLEAVELAND, of La Fayette, in the county of Tippecanoe, and State of Indiana, have invented a new and useful Improvement in Tools for Turning Shafting and Cutting Screws; and I do hereby declare that the following is a full, clear, and exact description of the same, reference being had to the annexed drawings making part of this specification.

This invention relates to improvements upon George H. Wells's screw-cutting tool, patented April 2, 1867.

The improvement consists in the adaptation of the stock by changes in its construction, to use on ordinary lathes, either for cutting screws or turning shafting, and secondly, in providing, for each of the cutters, set-screws which, acting independently, may be used for adjusting the cutters separately, while the whole are fed simultaneously by a screw acting upon the rest.

In the annexed drawings, A represents the ways of an ordinary lathe. B is the stock for holding the shaft to be cut; it is formed, as shown in the drawings, to slide on the ways, and having the front end turned upwards to support the jaw C, by which the rod to be cut is securely clamped to prevent vibration of the rod or shaft while subjected to the action of the cutters. D is the rest, which supports the cutters, and slides on a dovetailed projection, D', from the upper face of the stock B. It is regulated by a screw, E, by which it may be advanced or retracted, carrying with it the cutters. A round groove is cut in the top of the rest D, which catches the foot of the posts F. The cutting-tools, G, pass through slots in the posts, and are held firmly in their proper place by set-screws, H, passing down through the tops of the posts and bearing against the cutters. On releasing these set-screws the cutters may be independently regulated by the set-screws I, passing through lugs, I', attached to the rest D. The points of the set-screws I bear against the rear ends of the cutters.

By this arrangement the successive depth of cut of the various cutters in the series may be regulated as required, either to cut the thread of a screw or to turn off the surface of shafting.

What I claim as my invention, and desire to secure by Letters Patent, is—

1. The combination of the rest D, stock B, and jaw C, the cutters G, and the set-screws I, and lugs I', by which the cutters may be independently regulated in relation to one another, while the rest is adjustable, so as to move all the cutters simultaneously, substantially as described.

2. The stock B, when constructed as described, in combination with the rest, D, adjusting-screw E, and a series of cutters, G G, substantially as and for the purpose set forth.

In testimony whereof, I have signed my name to this specification in the presence of two subscribing witnesses.

JUDSON A. CLEAVELAND.

Witnesses:

JOHN L. MILLER,  
S. T. STALLARD.